

MRL Passenger Elevator

Hoistway Structure

Concrete Brick & Concrete Other

Unstandard Standard

NOTE

				Technical Requirement:		
HW	HOISTWAY WIDTH	CW	CAR INSIDE WIDTH	Type	TKJW 630 / 1.0 -VF	
HD	HOISTWAY DEPTH	CD	CAR INSIDE DEPTH	F/P/D	2 / 2 / 2	Door type Center open
OP	DOOR OPENING WIDTH	CH	CAR HEIGHT	load	630 kg	Speed 1.0 m/s
ROP	WALL OPENING WIDTH	MRW	MACHINE ROOM WIDTH	Machine	MONA 320	Roping 2:1
OPH	DOOR OPENING HEIGHT	MRD	MACHINE ROOM DEPTH	T/sheave	∅ 320	D/sheave ∅
OH	OVERHEAD HEIGHT	MRF	MACHINE ROOM HEIGHT	car sheave	∅ 320	CW sheave ∅ 320
CAR DBG	DISTANCE BETWEEN CAR GUIDE RAILS			Shaft	HW 1850 mm x HD 1800 mm	
CWT DBG	DISTANCE BETWEEN COUNTERWEIGHT GUIDE RAILS			Cabin	CW 1200 mm x CD 1250 mm	
				Door	OP 800 mm x OPH 2100 mm	

Compact type

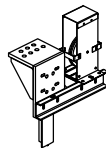

Speed limiter base detail

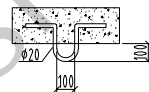

The hook

The hook(20kn indicate on the hook) by others

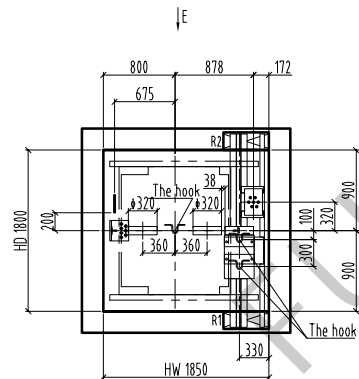

Overhead plan/1:60

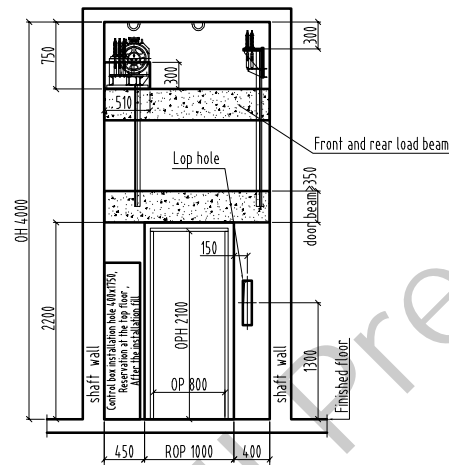

E/reserved hole/1:60

The other side door hole is symmetrically reserved according to E to the door hole

Bottom box Lop: 100x500 (base station) 100x400 (remaining stations)
No bottom box Lop hole: ∅50 hole

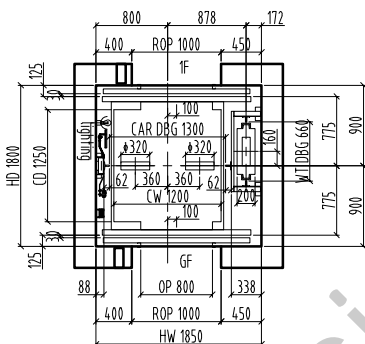

Hoistway plan/1:60

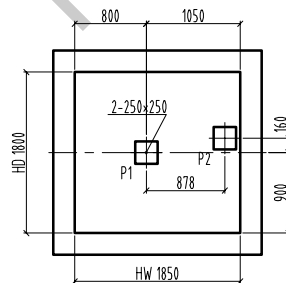

Pit plan/1:60

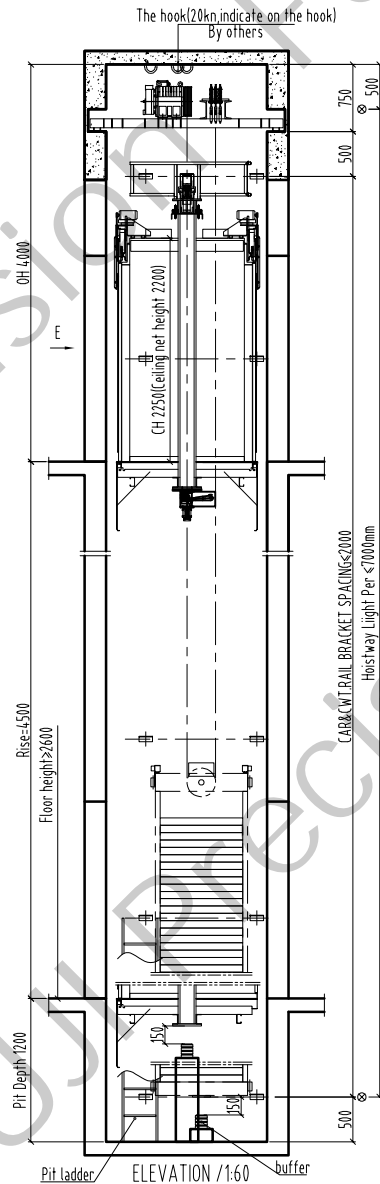

OH	4000
Rise	4500
26 F	
25 F	
24 F	
23 F	
22 F	
21 F	
20 F	
19 F	
18 F	
17 F	
16 F	
15 F	
14 F	
13 F	
12 F	
11 F	
10 F	
9 F	
8 F	
7 F	
6 F	
5 F	
4 F	
3 F	
2 F	
1 F	OH
GF	4500
Pit	1200
Floor	Height

Support Force (N)							
R1	R2	R3	R4	P1	P2	P3	P4
31400	39600			88000	68000		

Technical Requirement

- Power supply: machine room need equiped with power supply. Power supply box need be locked. Power supply should be 3P.5 wires, 380V 50Hz. Voltage tolerance $\pm 7\%$, input power more than 50% of motor power, also equiped with air switch same capacity with power supply, also allow the supplement leakage protector. When use VVVF, need use special leakage switch. Ground resistor should be < 4 Ω . It should use insulated conductor from floor to machine room. Keep separate for null wire and ground wire.
- Shaft requirement, it should be only for lift, can not install non-related device (pipe, cable, etc), and should keep the person entrance into. The shaft plan size mean the mm size measured by plumb line, tolerance ± 50 mm. Basically not allow the protruding beam and column. The proof pressure of shaft side should be ≥ 24 MPa. Recommend to use full concrete, can not use the reserved steel. In case use solid brick, it should use reserved steel or make the ring beam on the surface of reserved steel, height ≥ 300 mm. If use hollow brick, can choose C25 concrete fill into the wall, also make the ring beam on the surface of reserved steel, height ≥ 300 mm. If the shaft front wall is brick construction, it should make the concrete beam upsid of door hole to fix the landing door bracket, height ≥ 300 mm. If have the requirement in the drawing, it should make the concrete in the entrance of hall door. It should equiped with lamp, brightness ≥ 50 lx, install the lamp at 0.5m from the top and the bottom, in the middle each lamp at ≤ 1 m. The buffer block should be made accompany with special person. Before that need make the reserved 24 pcs joint bar $\geq \phi 12$ mm, height ≥ 500 mm from the pit floor, and should water proof. Keep the space for person entrance. Pit ladder is by user. Should installed it in a suitable place. If there have basement downside of the pit should make the buffer block extend to the solid floor downside. If the floor distance between 2 floor > 1 m, should set the safe door with the width 350mm, height 1800mm.
- Machine room requirement (not for MRL). It had the passageway for the traction machine, keep the entrance unblocked. The door opens outward, also can be locked. Installed the fan, keep the humidity $< 85\%$, temperature $+5 \sim -40^\circ$, surrounding the reserved hole should make the 50mm hole, keep the floor plan, also bear the load 700kg/m². The motor or beam should be supported in the concrete block, this concrete block should extend to the building beam or bearing wall. Bearing side should make the reserved same side steel, thickness 2mm, bearing side thickness should over the wall thickness 20mm, total thickness more than 75mm. Standard wall 200mm, recommed the bearing wall thickness ≥ 200 mm. The hook in the machine room should indicate the max. load. It should install the ladder and barrier in case have stair.

Drawing		approver	
Drawing No.	FTKW 630 -03		
manufacturing no.			
Project name			

FUJI PRECISION